

---

---

## Reduction of warranty costs

---

Estimates of global spend on warranty claims in the automotive industry frequently run between \$45 billion and \$50 billion. A large fraction of these costs incur for "No Trouble Found" (NTF) - components replaced during a service event, which actually meet all the requirements of good components.

The mentioned fault detection and diagnosis system comprises a sophisticated on-board and offboard fault detection and fault diagnosis module for a common rail injection system based on the available sensor measurements. It can make a contribution to significantly reduce warranty costs by an earlier detection and more accurate diagnosis of the underlying fault. Various faults are recognized by the fault detection and diagnosis system. For example faulty injectors, a clogged fuel filter, a faulty common rail pressure sensor value and leaks can be detected and diagnosed.

Besides identifying the location of the occurring fault, the fault detection and diagnosis system further provides precious information with respect to the supervised components, stating where a fault has most likely *not* occurred. This information can be utilized to prevent the precautionary yet cost-intensive replacement of functional components and can hence contribute to a considerable reduction of the high NTF rates.

Due to the modular architecture of the fault detection and fault diagnosis module it is adaptable to a large range of different system configurations.

For the implementation of the fault detection and diagnosis module no additional hardware is needed. The module merely use the measured signals that are already available from the common rail injection system.

A patent application has been filed for the fault detection and diagnosis module.

We encourage you to contact us for more information.

---

---

---

## Contact

---

Technische Universität Darmstadt  
Institute of Automatic Control  
Research group for Control Engineering and Process Automation  
Prof. Dr.-Ing. Dr. h.c. Rolf Isermann

Landgraf-Georg-Straße 4  
Gebäude S3|10, 5. Stock, Raum 512  
D-64283 Darmstadt  
Phone +49 06151 16-2114  
Fax +49 6151 16-6114  
risermann@iat.tu-darmstadt.de

---

---

## Literature

---

Sebastian Clever and Rolf Isermann.  
Model-Based Fault Detection and Diagnosis for Common-Rail Injection Systems.  
MTZ worldwide, 2, 2010.

Sebastian Clever.  
Model-Based Fault Detection and Diagnosis for Common Rail Diesel Engines.  
Institute of Automatic Control, TU Darmstadt, expected 2010.

# Fault Detection and Diagnosis Module for a Common Rail Injection System

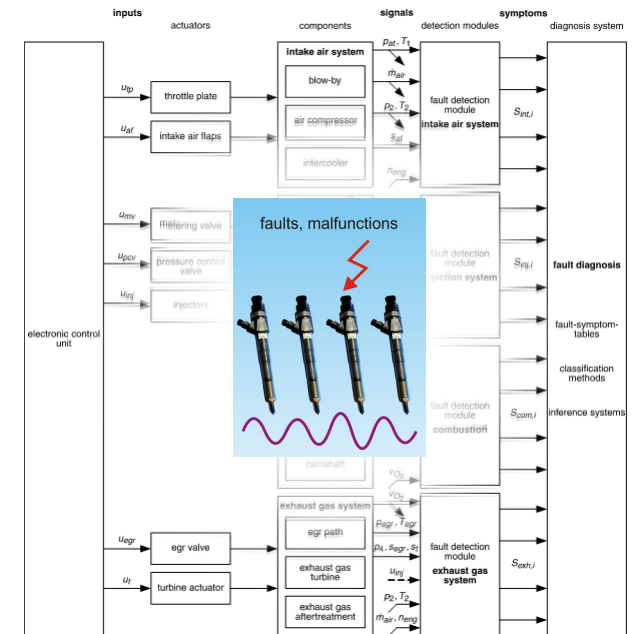

## Common Rail Injection System

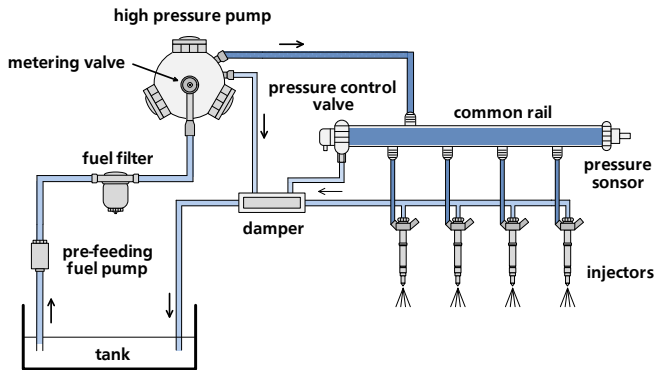

In a common rail injection system fuel is accumulated under high pressure in a pressure accumulator - referred to as common rail. This approach enables a time-independent fuel delivery to the injectors and allows for a large scale of different pressure levels.

The fuel is delivered from the tank and pre-compressed by an electrical fuel pump. After filtration the fuel flows to the high pressure pump. There the fuel is compressed to the common rail pressure level (300-1800bar) and then discharged to the common rail. From there the fuel is injected into the cylinders each time an injector opens.

The common rail pressure is measured by a high pressure sensor. The fuel pressure inside the common rail is either controlled by a metering valve or by a pressure control valve. A number of common rail injections systems, however, employ a combination of both valves. On the low pressure side the metering valve acts on the volume flow delivered by the high pressure pump. The pressure control valve is located on the common rail and from there it directly controls the pressure on the high pressure side.

All components may be affected by various faults, such as faults of the high pressure pump, the common rail pressure sensor, the fuel filter and the injectors. The aim of the presented fault detection and diagnosis system is to detect and to diagnose these faults as early as possible.

## Fault Detection Module

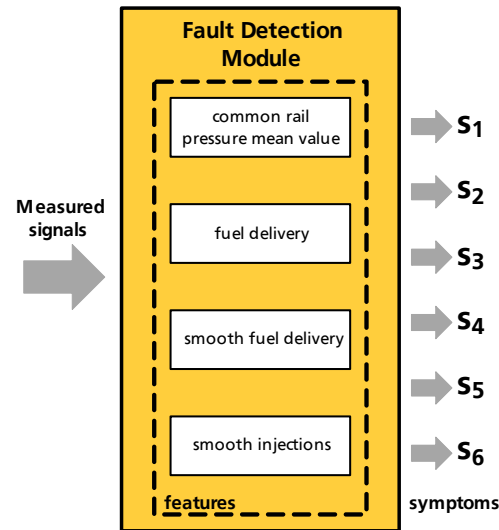

Model-based fault detection algorithms utilize the analytical process knowledge about the dependencies between several measurable signals of the process. The entire process consists of actuators, the physical process and several sensors.

The measured signals are used to calculate fault detection *features*. The calculation of the individual features can be conducted by independent fault detection modules. These modules are based on *process model-based* or *signal model-based* fault detection approaches and are implemented preferably on-board.

The features are designed such that in the event of an occurring fault their value differs from the corresponding value of the fault free process.

Based on the deviation of the feature values with respect to the fault free process *symptoms* are derived.

## Fault Diagnosis Module

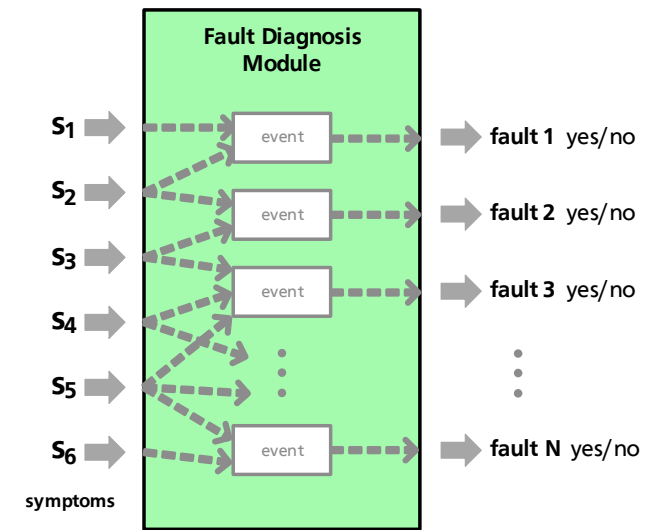

The symptoms derived from one or several fault detection modules yield various information about the actual state of the process and are processed in a common diagnosis system. This allows relating the information of all symptoms in order to enclose the occurring fault.

For the diagnosis of the faults it is feasible to employ fault diagnosis systems that are either based on classification methods (SVM, geometric approaches) or inference methods (Fuzzy systems, fault trees). The use of either approach is adapted to the individual requirements.

The fault diagnosis module can be implemented on-board or offboard and is able to conclude about the underlying fault.

Moreover, the fault diagnosis module also provides crucial information as to where a fault has most likely *not* occurred. This information is particularly valuable as it can prevent the replacement of functional components.